

# **DUTCH TIME AND FREQUENCY NETWORK FOR RESEARCH AND EDUCATION**

Sander Klemann  
Productmanager Netwerk Diensten

Paul Klop  
Technical product manager

**SURF**

# From ad-hoc links to a permanent T&F Network

## Milestone: 29 January 2026: Presentation first Dutch Time and

**GEANT**  
16,322 followers  
2w • Edited •

The launch of the Dutch Time & Frequency network for #Research & #Education

Last month, **Vrije Universiteit Amsterdam (VU Amsterdam)** brought together researchers, network engineers and metrologists to celebrate the development of precision timing over Dutch R&E networks made possible by **SURF** and their research partners across the Netherlands.

With Time & Frequency now part of SURF's portfolio, connected institutions can receive highly precise time and frequency signals directly over fibre, enabled by White Rabbit technology and 24/7 monitoring.

Why this matters:

- Supports timing-critical research across disciplines
- Strengthens national timekeeping together with **VSL National Metrology Institute**
- Contributes to Europe's evolving timing ecosystem, alongside the White Rabbit Collaboration at CERN and initiatives across our GEANT community

Across Europe, NRENs are increasingly supporting precision timing, quantum networking and resilient digital infrastructure, positioning research and education networks at the heart of a shared European timing ecosystem.

Read more in the recap post by **Domenico (Dom) Vicinanza** and **Karl Meyer**: <https://lnkd.in/eVCDJZB>

**SURF**  
24,239 volgers  
1 mnd • Bewerkt •

Met SURF Time&Frequency krijgen onderzoekers toegang tot ongeëvenaarde meetprecisie via glasvezel.

Universitair docent **Jeroen Koelemeij** van de **Vrije Universiteit Amsterdam** geeft de dienst om atoomtrillingen tot 12 cijfers achter de komma te meten.

Ook wordt het onderzocht als veiliger alternatief voor gps. Meer weten over de technologie?

Lees het praktijkverhaal: <https://lnkd.in/eHC-w5aQ>

#gps

**Jeroen Koelemeij** • 1st  
Associate Professor at Vrije Universiteit Amsterdam (VU Amsterdam)  
1mo • Edited •

It was wonderful to celebrate the launch of the SURF Time&Frequency Network yesterday at Vrije Universiteit Amsterdam! Great to see so many of those who contributed to the underlying technology and infrastructure, including visitors from abroad - Amanda Diez of CERN and Domenico Vicinanza of GEANT - and listen to inspiring contributions by Paul Klop of SURF, Jacoline Boonman of VSL, and Amanda Diez on behalf of CERN.

With the event being hosted at VU Amsterdam, our guests had an opportunity to see several cutting-edge use cases of the SURF Time&Frequency Network and its traceable connection to UTC(VSL) in the laboratories of the Department of Physics & Astronomy at VU. After 15 years of collaboration this represents a fantastic milestone - and an excellent starting point for new endeavours in science and engineering in the years to come!

**SURF** Services Topics  
News Agenda About SURF NL



**Available to all scientists: the most accurate clock in the Netherlands**

SURF, together with the White Rabbit Collaboration and the Dutch Metrology Institute VSL, has realised the first nationwide scientific time and frequency network in the Netherlands. VSL's highly precise time and frequency signal is available from today at 11 different locations within the SURF network.



with SURF and 2 others  
You and 76 others  
1 comment • 7 reposts

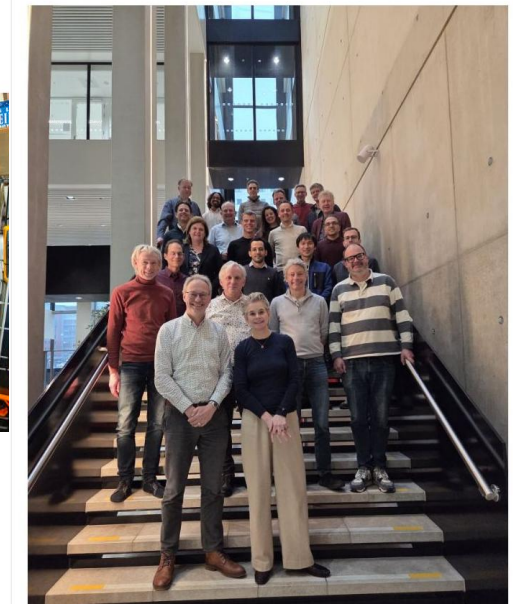

# From ad-hoc links to a permanent T&F Network

- Historical situation
  - Built per experiment, on demand
  - Required dedicated engineering, routing, and calibration
- Growth in demand
  - Increasing number of timing-critical experiments over time
  - Requests coming from different research members and locations
- Conclusion
  - Need for precise timing is continuous
  - This justified building a **permanent national T&F backbone**

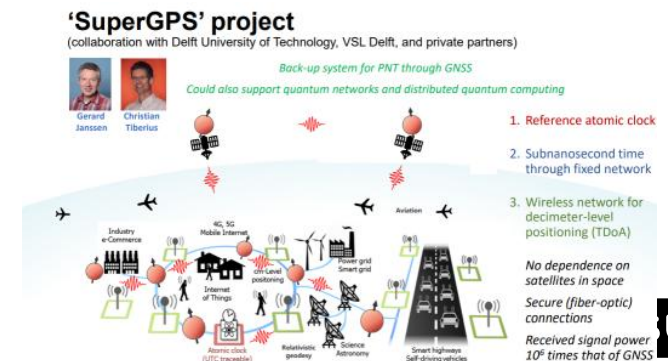
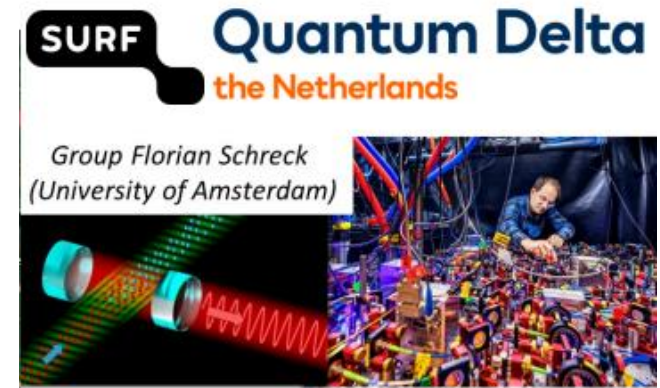



# What did we build and how did we get there?

- Step 3 – Developing of calibration methodology
- Step 4 – Integration into operations

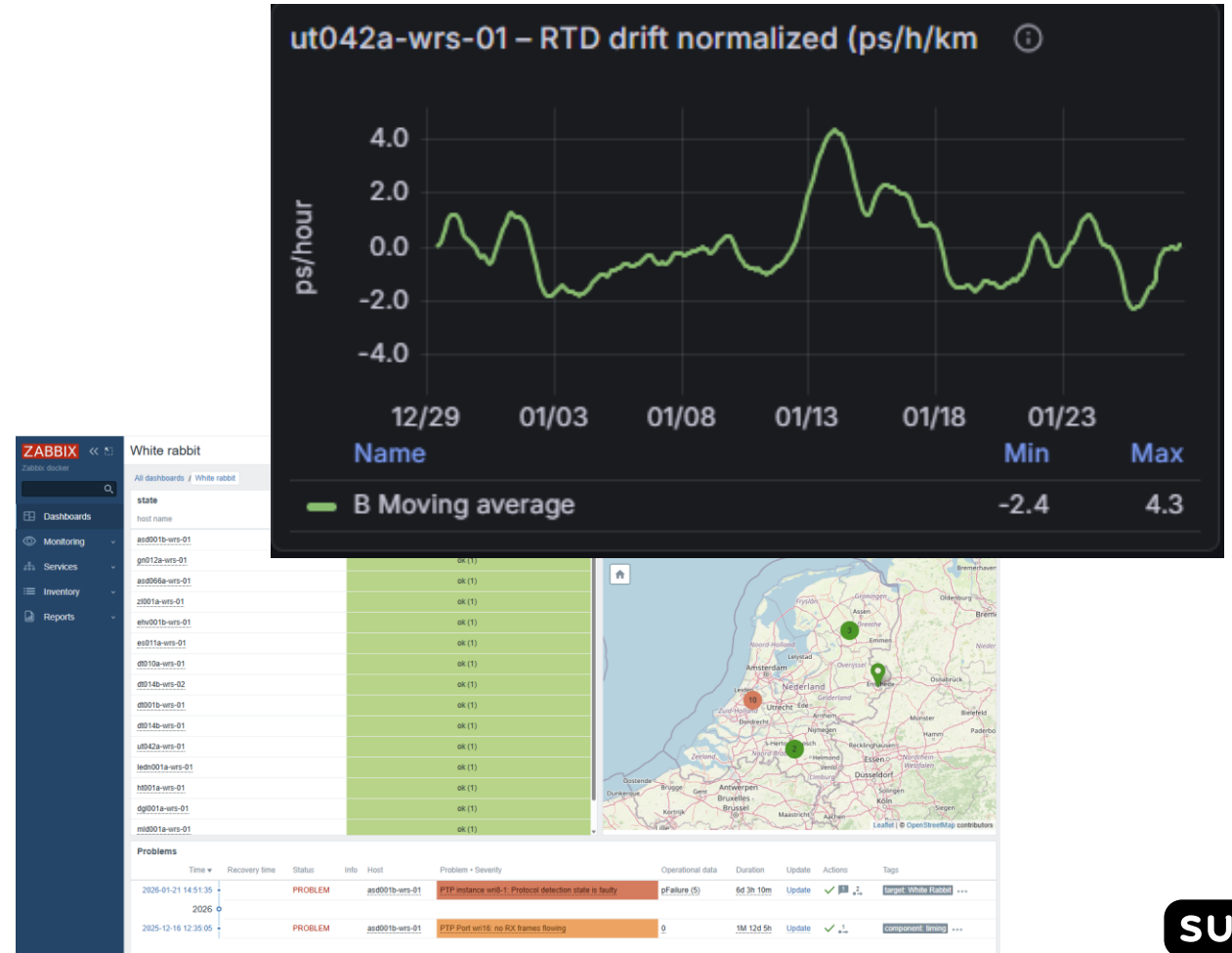

# Challenges and key decisions

## Technology choices

- Proprietary solutions <-> open hardware and open firmware
- Risk of vendor lock-in <-> internal expertise requirements
- Ensuring interoperability across different WR implementations

## Support and sustainability

- Limited commercial support for niche timing technology
- Dependence on community knowledge and expert partners
- Need to build in-house operational competence

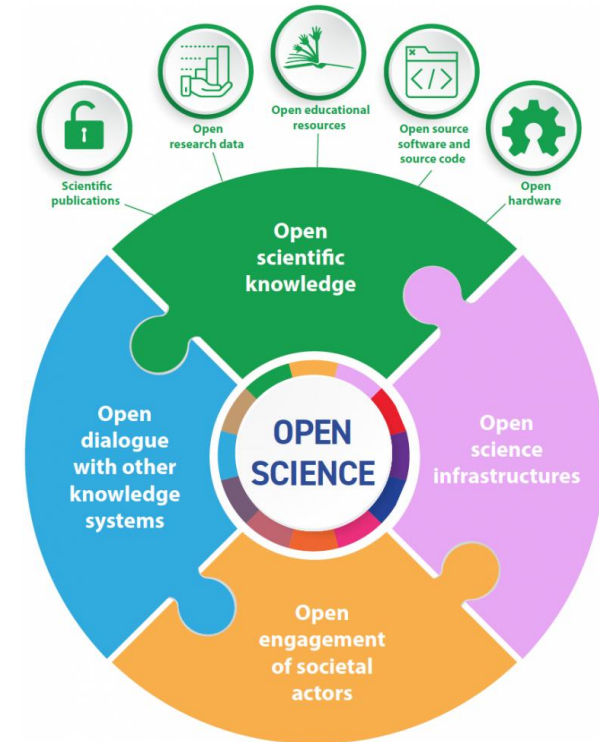

# Challenges and key decisions

- Calibration complexity
- Meeting experiment expectations
  - Risk of “it syncs, but is it good enough?”
- Integration with SURF network operations

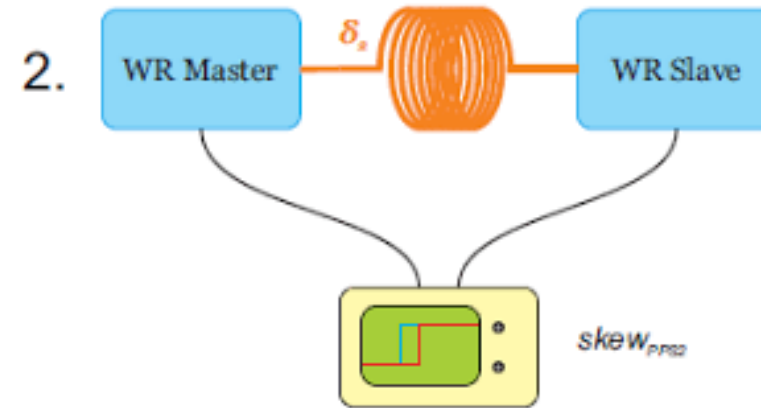

# Collaboration as necessity, not luxury

- **The collaboration was essential**
  - No single party covers timing, optical transport, and operations
  - Many issues only visible at system level
- **Key partners**
  - NMI (VSL) NREN (CESNET)
- **Open community**
  - We joined the White Rabbit Collaboration as a (counsel) member and participate in the community



# Where are we now, and what are we proud of ?

- **Stable White Rabbit backbone**
- **Built on SURF network**
- **24/7 monitoring and operations**
  - Continuous monitoring of synchronization status and link behavior
  - Faster detection and resolution of timing-related issues
- **What this enables**
  - Predictable timing performance for experiments



# Partnerships and future outlook for Time & Frequency

- Partnerships remain essential



- Evolving requirements

- New experiments push for higher accuracy and longer distances
- Increasing interest from quantum communication and sensing projects

- Future direction

- Expansion to more sites and cross-border interconnection
- Preparation for ultra stable optical carrier transfer alongside time distribution



# SURF

USE-CASES

38

37

37

1310

ED

GBC PHOTONICS

SURF

GBC PHOTONICS

IN/OUT

IN/OUT

SURF

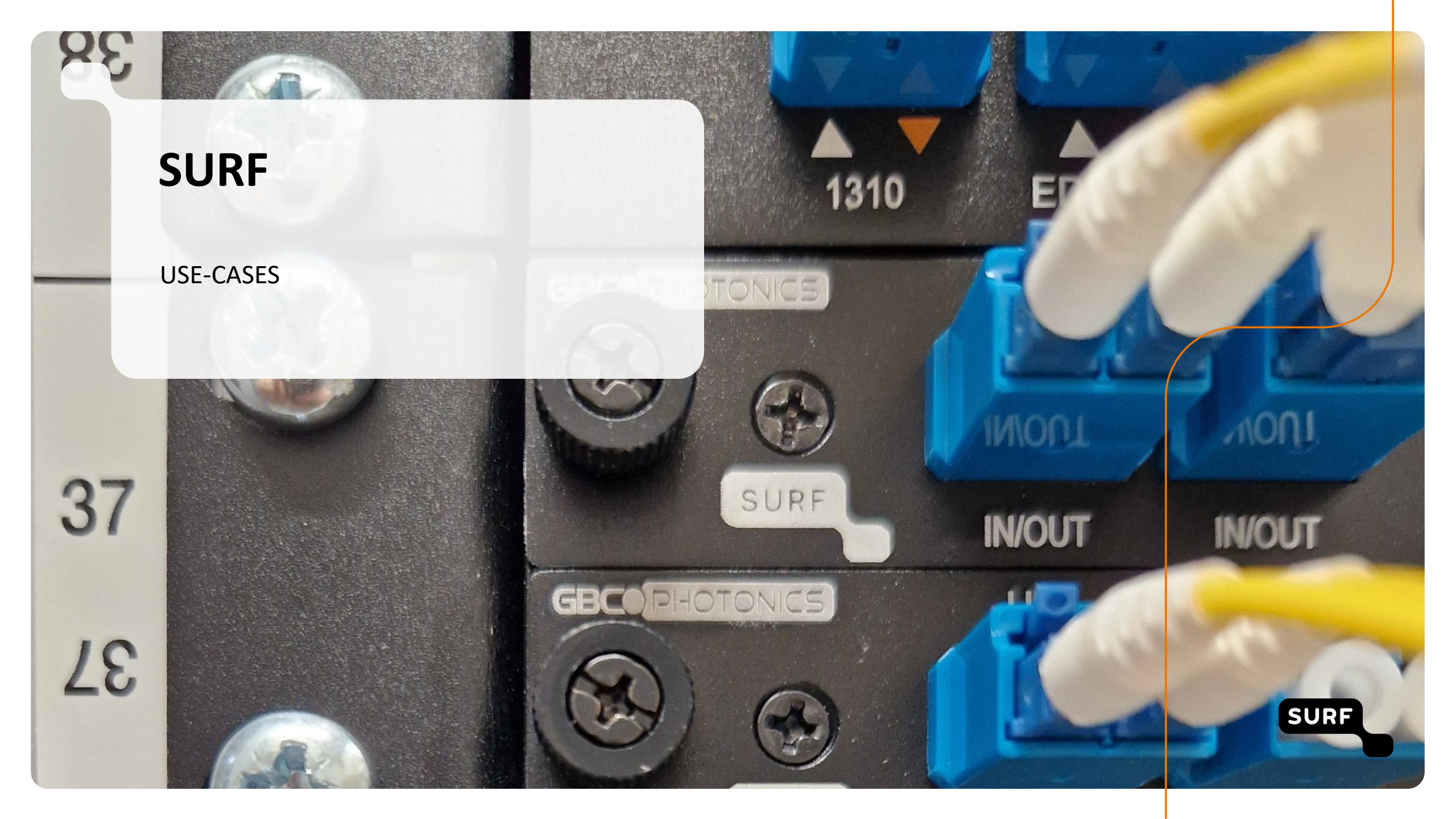

# “Super-GPS” An urban navigation system with 10-centimeter accuracy

- [Colaboration between TUdelft, VU University, VSL and SURF](#)
- Use Mobile Telecommunication Network to distribute Atomic Clock
- More precise time is better accuracy
- Publication in Nature last year
  - Koelemeij, J.C.J., Dun, H., Diouf, C.E.V. *et al.* A hybrid optical–wireless network for decimetre-level terrestrial positioning. *Nature* **611**, 473–478 (2022)

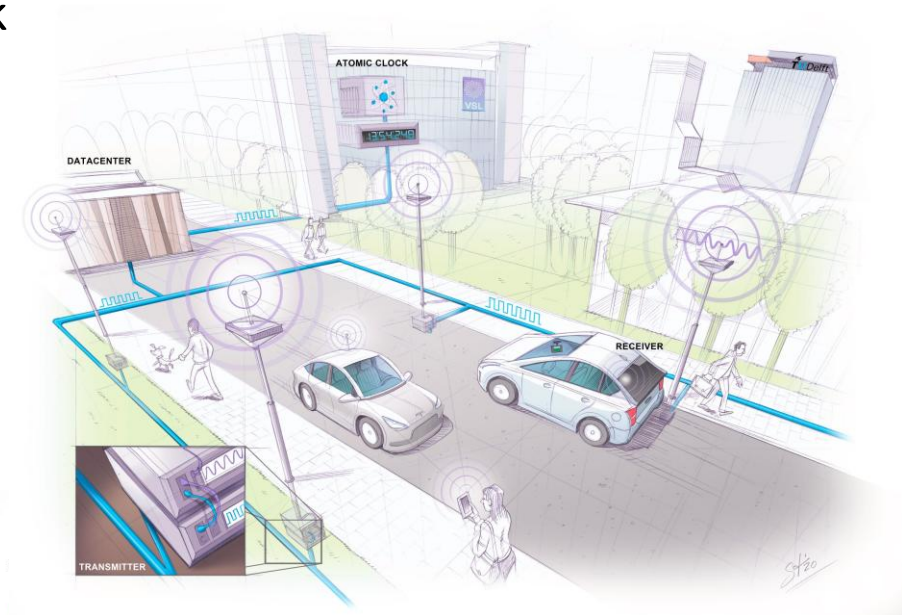

# The journey still continues 2021 -

- QuantumDeltaNL research (National Growth Fund)
- Distributing *optical atomic clocks* via SURF
- UvA: **Sumit Sarkar, Klaasjan van Druten, Florian Schreck**
- VU: **Sougandh Kannoth Mavila, Rodrigo Escudero González**
- VSL: **Martine Kuiper, Erik Dierikx**

1 **Picosecond-range network time scale based on an ensemble of atomic**  
 2 **clocks**

3 R. González Escudero<sup>1</sup>, S. Kannoth Mavila<sup>1</sup>, M.A. Weiss<sup>2</sup>, F.M.J. Cozijn<sup>1</sup>, K. Steinebach<sup>1</sup>, K.S.E. Eikema<sup>1</sup>,  
 4 E.F. Dierikx<sup>3</sup>, Y. Xie<sup>3</sup>, S. Klemann<sup>4</sup>, P. Klop<sup>4</sup>, S. Sarkar<sup>5</sup>, N.J. van Druten<sup>5</sup>, F. Schreck<sup>5</sup> & J.C.J. Koelemeij<sup>1</sup> 

5 <sup>1</sup>Vrije Universiteit Amsterdam, Amsterdam, The Netherlands. <sup>2</sup>Marc Weiss Consulting LLC, Aptos, CA,  
 6 United States of America. <sup>3</sup>VSL, Delft, The Netherlands. <sup>4</sup>SURF, Utrecht, The Netherlands. <sup>5</sup>University of  
 7 Amsterdam, Amsterdam, The Netherlands.

- **Robust sub-nanosecond network clocks** based on atomic clock ensembles and WR

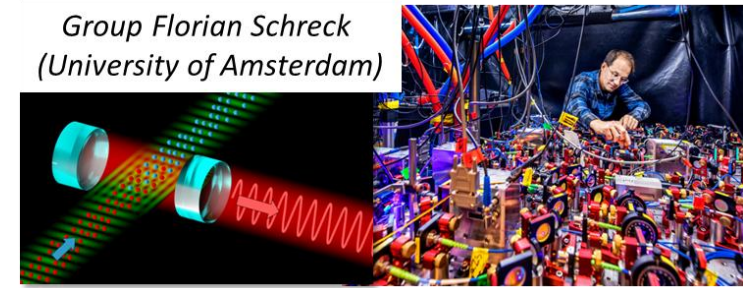

Group Florian Schreck  
(University of Amsterdam)

- Towards European T&F infrastructure: GÉANT C-TFN, FOREST

- VSL: **Jacoline Boonman, Erik Dierikx**
- SURF: Sander Klemann, Paul Klop, **Karin Wessel, Migiel de Vos, Maurice Bouwhuis, Robin Janssen**
- **European collaborators**

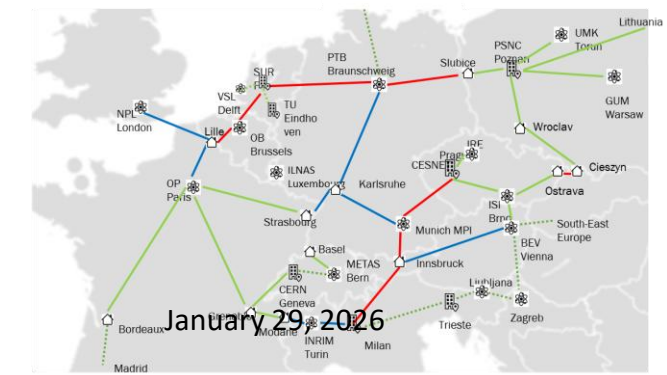

# Use case 1 (VU, UvA, VSL, SURF)

- Robust sub-nanosecond network clocks based on atomic clock ensembles and White Rabbit

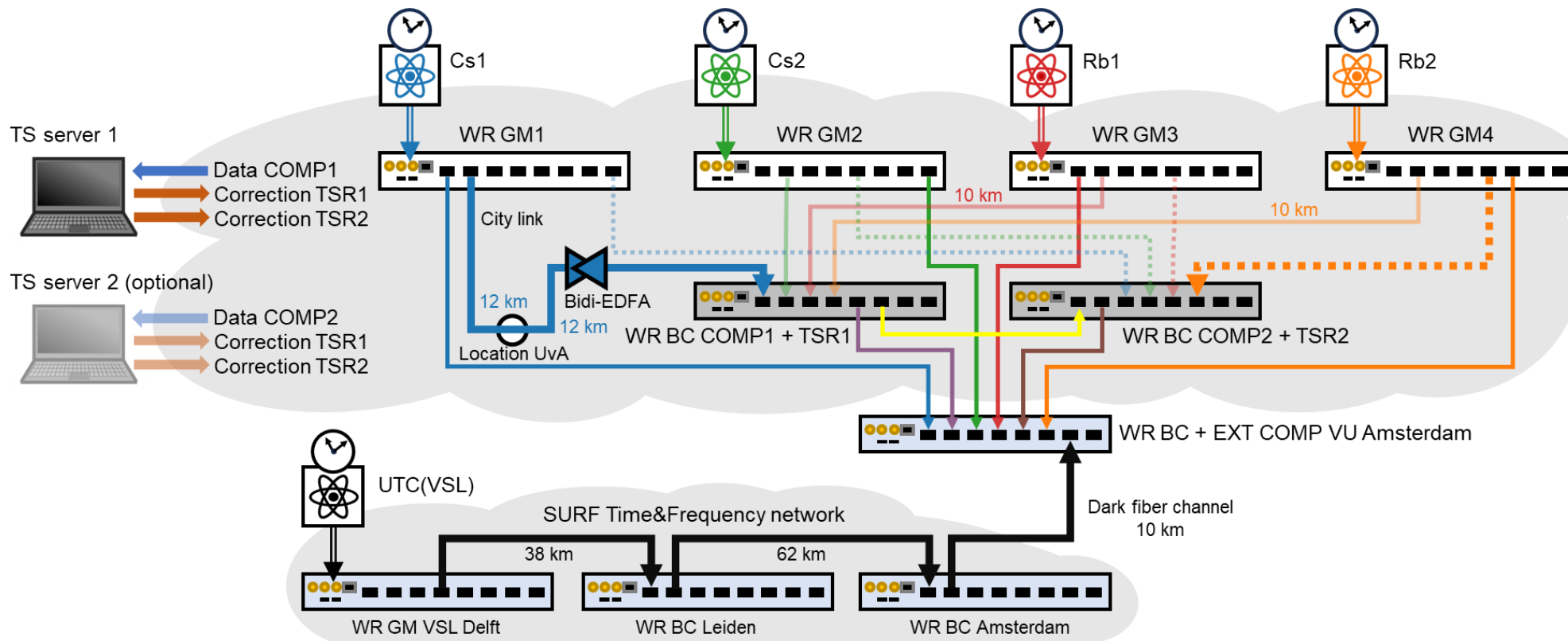

# LOFAR 2.0 Radio telescope Use Case

- LOFAR (Low Frequency Array) is currently the largest radio telescope operating at the lowest frequencies that can be observed from Earth. Unlike single-dish telescope, LOFAR is a multipurpose sensor network, with an innovative computer and network infrastructure that can handle extremely large data volumes.



# Calibrated image without correction for clock & ionosphere

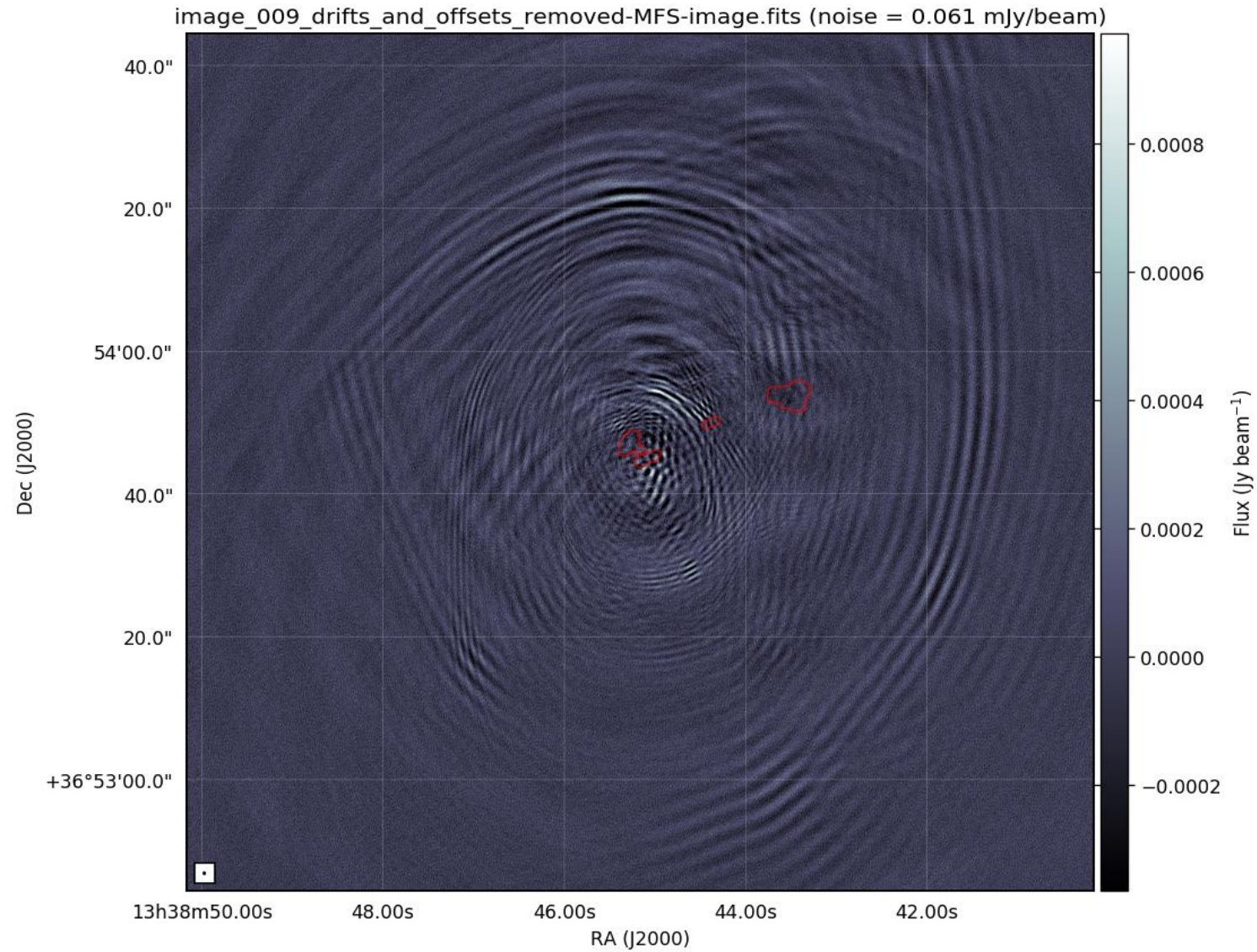

# Calibrated image including correction for the clock offset and clock drifts

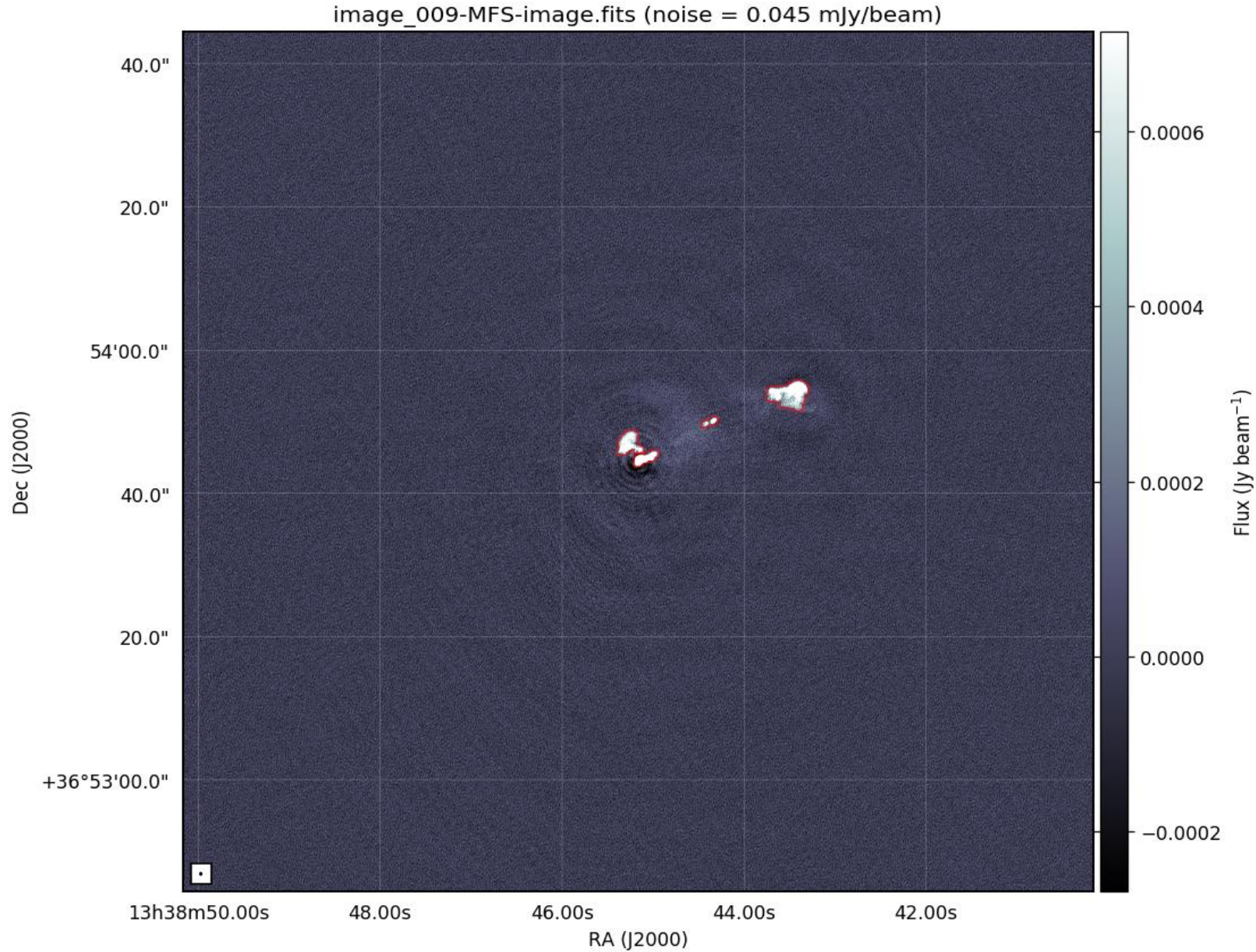



**THANK YOU FOR  
YOUR ATTENTION**



**Driving innovation together**

Driving innovation together

